

## ELECTRIC CURRENT IN CONDUCTORS CHAPTER - 32

1.  $Q(t) = At^2 + Bt + c$

a)  $At^2 = Q$

$$\Rightarrow A = \frac{Q}{t^2} = \frac{A'T'}{T^{-2}} = A'T^{-1}$$

b)  $Bt = Q$

$$\Rightarrow B = \frac{Q}{t} = \frac{A'T'}{T} = A$$

c)  $C = [Q]$

$$\Rightarrow C = A'T'$$

d) Current  $i = \frac{dQ}{dt} = \frac{d}{dt}(At^2 + Bt + C)$

$$= 2At + B = 2 \times 5 \times 5 + 3 = 53 \text{ A.}$$

2. No. of electrons per second =  $2 \times 10^{16}$  electrons / sec.

$$\text{Charge passing per second} = 2 \times 10^{16} \times 1.6 \times 10^{-9} \frac{\text{coulomb}}{\text{sec}}$$

$$= 3.2 \times 10^{-9} \text{ Coulomb/sec}$$

$$\text{Current} = 3.2 \times 10^{-3} \text{ A.}$$

3.  $i' = 2 \mu\text{A}$ ,  $t = 5 \text{ min} = 5 \times 60 \text{ sec.}$

$$q = i t = 2 \times 10^{-6} \times 5 \times 60$$

$$= 10 \times 60 \times 10^{-6} \text{ C} = 6 \times 10^{-4} \text{ C}$$

4.  $i = i_0 + \alpha t$ ,  $t = 10 \text{ sec}$ ,  $i_0 = 10 \text{ A}$ ,  $\alpha = 4 \text{ A/sec.}$

$$q = \int_0^t i dt = \int_0^t (i_0 + \alpha t) dt = \int_0^t i_0 dt + \int_0^t \alpha t dt$$

$$= i_0 t + \alpha \frac{t^2}{2} = 10 \times 10 + 4 \times \frac{10 \times 10}{2}$$

$$= 100 + 200 = 300 \text{ C.}$$

5.  $i = 1 \text{ A}$ ,  $A = 1 \text{ mm}^2 = 1 \times 10^{-6} \text{ m}^2$

$$f' \text{ cu} = 9000 \text{ kg/m}^3$$

Molecular mass has  $N_0$  atoms

$$= m \text{ Kg has } (N_0/M \times m) \text{ atoms} = \frac{N_0 A i 9000}{63.5 \times 10^{-3}}$$

No. of atoms = No. of electrons

$$n = \frac{\text{No. of electrons}}{\text{Unit volume}} = \frac{N_0 A i f}{m A l} = \frac{N_0 f}{M}$$

$$= \frac{6 \times 10^{23} \times 9000}{63.5 \times 10^{-3}}$$

$$i = V_d n A e.$$

$$\Rightarrow V_d = \frac{i}{n A e} = \frac{1}{\frac{6 \times 10^{23} \times 9000}{63.5 \times 10^{-3}} \times 10^{-6} \times 1.6 \times 10^{-19}}$$

$$= \frac{63.5 \times 10^{-3}}{6 \times 10^{23} \times 9000 \times 10^{-6} \times 1.6 \times 10^{-19}} = \frac{63.5 \times 10^{-3}}{6 \times 9 \times 1.6 \times 10^{26} \times 10^{-19} \times 10^{-6}}$$

$$= \frac{63.5 \times 10^{-3}}{6 \times 9 \times 1.6 \times 10^{-16}} = \frac{63.5 \times 10^{-3}}{6 \times 9 \times 16}$$

$$= 0.074 \times 10^{-3} \text{ m/s} = 0.074 \text{ mm/s.}$$

6.  $\ell = 1 \text{ m}, r = 0.1 \text{ mm} = 0.1 \times 10^{-3} \text{ m}$

$R = 100 \Omega, f = ?$

$\Rightarrow R = f \ell / a$

$$\Rightarrow f = \frac{Ra}{\ell} = \frac{100 \times 3.14 \times 0.1 \times 0.1 \times 10^{-6}}{1}$$

$$= 3.14 \times 10^{-6} = \pi \times 10^{-6} \Omega\text{-m.}$$

7.  $\ell' = 2 \ell$

volume of the wire remains constant.

$A \ell = A' \ell'$

$\Rightarrow A \ell = A' \times 2 \ell$

$\Rightarrow A' = A/2$

$f =$  Specific resistance

$R = \frac{f \ell}{A}; R' = \frac{f \ell'}{A'}$

$100 \Omega = \frac{f 2 \ell}{A/2} = \frac{4 f \ell}{A} = 4R$

$\Rightarrow 4 \times 100 \Omega = 400 \Omega$

8.  $\ell = 4 \text{ m}, A = 1 \text{ mm}^2 = 1 \times 10^{-6} \text{ m}^2$

$I = 2 \text{ A}, n/V = 10^{29}, t = ?$

$i = n A V_d e$

$\Rightarrow e = 10^{29} \times 1 \times 10^{-6} \times V_d \times 1.6 \times 10^{-19}$

$$\Rightarrow V_d = \frac{2}{10^{29} \times 10^{-6} \times 1.6 \times 10^{-19}}$$

$$= \frac{1}{0.8 \times 10^4} = \frac{1}{8000}$$

$t = \frac{\ell}{V_d} = \frac{4}{1/8000} = 4 \times 8000$

$= 32000 = 3.2 \times 10^4 \text{ sec.}$

9.  $f_{\text{cu}} = 1.7 \times 10^{-8} \Omega\text{-m}$

$A = 0.01 \text{ mm}^2 = 0.01 \times 10^{-6} \text{ m}^2$

$R = 1 \text{ K}\Omega = 10^3 \Omega$

$R = \frac{f \ell}{a}$

$\Rightarrow 10^3 = \frac{1.7 \times 10^{-8} \times \ell}{10^{-6}}$

$\Rightarrow \ell = \frac{10^3}{1.7} = 0.58 \times 10^3 \text{ m} = 0.6 \text{ km.}$

10.  $dR$ , due to the small strip  $dx$  at a distance  $x$   $d = R = \frac{f dx}{\pi y^2} \dots(1)$

$\tan \theta = \frac{y-a}{x} = \frac{b-a}{L}$

$\Rightarrow \frac{y-a}{x} = \frac{b-a}{L}$

$\Rightarrow L(y-a) = x(b-a)$

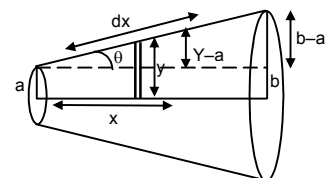

$$\Rightarrow Ly - La = xb - xa$$

$$\Rightarrow L \frac{dy}{dx} - 0 = b - a \quad (\text{diff. w.r.t. } x)$$

$$\Rightarrow L \frac{dy}{dx} = b - a$$

$$\Rightarrow dx = \frac{Ldy}{b-a} \quad \dots(2)$$

Putting the value of dx in equation (1)

$$dR = \frac{fLdy}{\pi y^2(b-a)}$$

$$\Rightarrow dR = \frac{fl}{\pi(b-a)} \frac{dy}{y^2}$$

$$\Rightarrow \int_0^R dR = \frac{fl}{\pi(b-a)} \int_a^b \frac{dy}{y^2}$$

$$\Rightarrow R = \frac{fl}{\pi(b-a)} \frac{(b-a)}{ab} = \frac{fl}{\pi ab}$$

11.  $r = 0.1 \text{ mm} = 10^{-4} \text{ m}$

$R = 1 \text{ K}\Omega = 10^3 \Omega, V = 20 \text{ V}$

a) No. of electrons transferred

$$i = \frac{V}{R} = \frac{20}{10^3} = 20 \times 10^{-3} = 2 \times 10^{-2} \text{ A}$$

$$q = it = 2 \times 10^{-2} \times 1 = 2 \times 10^{-2} \text{ C.}$$

$$\text{No. of electrons transferred} = \frac{2 \times 10^{-2}}{1.6 \times 10^{-19}} = \frac{2 \times 10^{-17}}{1.6} = 1.25 \times 10^{17}.$$

b) Current density of wire

$$\begin{aligned} &= \frac{i}{A} = \frac{2 \times 10^{-2}}{\pi \times 10^{-8}} = \frac{2}{3.14} \times 10^{+6} \\ &= 0.6369 \times 10^{+6} = 6.37 \times 10^5 \text{ A/m}^2. \end{aligned}$$

12.  $A = 2 \times 10^{-6} \text{ m}^2, I = 1 \text{ A}$

$f = 1.7 \times 10^{-8} \Omega\text{-m}$

$E = ?$

$$R = \frac{f\ell}{A} = \frac{1.7 \times 10^{-8} \times \ell}{2 \times 10^{-6}}$$

$$V = IR = \frac{1 \times 1.7 \times 10^{-8} \times \ell}{2 \times 10^{-6}}$$

$$E = \frac{dV}{dL} = \frac{V}{l} = \frac{1.7 \times 10^{-8} \times \ell}{2 \times 10^{-6} \ell} = \frac{1.7}{2} \times 10^{-2} \text{ V/m}$$

$$= 8.5 \text{ mV/m.}$$

13.  $l = 2 \text{ m}, R = 5 \Omega, i = 10 \text{ A}, E = ?$

$$V = iR = 10 \times 5 = 50 \text{ V}$$

$$E = \frac{V}{l} = \frac{50}{2} = 25 \text{ V/m.}$$

14.  $R'_{Fe} = R_{Fe} (1 + \alpha_{Fe} \Delta\theta), R'_{Cu} = R_{Cu} (1 + \alpha_{Cu} \Delta\theta)$

$$R'_{Fe} = R'_{Cu}$$

$$\Rightarrow R_{Fe} (1 + \alpha_{Fe} \Delta\theta) = R_{Cu} (1 + \alpha_{Cu} \Delta\theta)$$

$$\begin{aligned} &\Rightarrow 3.9 [1 + 5 \times 10^{-3} (20 - \theta)] = 4.1 [1 + 4 \times 10^{-3} (20 - \theta)] \\ &\Rightarrow 3.9 + 3.9 \times 5 \times 10^{-3} (20 - \theta) = 4.1 + 4.1 \times 4 \times 10^{-3} (20 - \theta) \\ &\Rightarrow 4.1 \times 4 \times 10^{-3} (20 - \theta) - 3.9 \times 5 \times 10^{-3} (20 - \theta) = 3.9 - 4.1 \\ &\Rightarrow 16.4(20 - \theta) - 19.5(20 - \theta) = 0.2 \times 10^3 \\ &\Rightarrow (20 - \theta) (-3.1) = 0.2 \times 10^3 \\ &\Rightarrow \theta - 20 = 200 \\ &\Rightarrow \theta = 220^\circ\text{C}. \end{aligned}$$

15. Let the voltmeter reading when the voltage is 0 be X.

$$\begin{aligned} \frac{I_1 R}{I_2 R} &= \frac{V_1}{V_2} \\ \Rightarrow \frac{1.75}{2.75} &= \frac{14.4 - V}{22.4 - V} \Rightarrow \frac{0.35}{0.55} = \frac{14.4 - V}{22.4 - V} \\ \Rightarrow \frac{0.07}{0.11} &= \frac{14.4 - V}{22.4 - V} \Rightarrow \frac{7}{11} = \frac{14.4 - V}{22.4 - V} \\ \Rightarrow 7(22.4 - V) &= 11(14.4 - V) \Rightarrow 156.8 - 7V = 158.4 - 11V \\ \Rightarrow (7 - 11)V &= 156.8 - 158.4 \Rightarrow -4V = -1.6 \\ \Rightarrow V &= 0.4 \text{ V}. \end{aligned}$$

16. a) When switch is open, no current passes through the ammeter. In the upper part of the circuit the Voltmeter has  $\infty$  resistance. Thus current in it is 0.

$\therefore$  Voltmeter read the emf. (There is not Pot. Drop across the resistor).

- b) When switch is closed current passes through the circuit and if its value of i.

The voltmeter reads

$$\varepsilon - ir = 1.45$$

$$\Rightarrow 1.52 - ir = 1.45$$

$$\Rightarrow ir = 0.07$$

$$\Rightarrow 1 r = 0.07 \Rightarrow r = 0.07 \Omega.$$

17.  $E = 6 \text{ V}$ ,  $r = 1 \Omega$ ,  $V = 5.8 \text{ V}$ ,  $R = ?$

$$I = \frac{E}{R+r} = \frac{6}{R+1}, V = E - Ir$$

$$\Rightarrow 5.8 = 6 - \frac{6}{R+1} \times 1 \Rightarrow \frac{6}{R+1} = 0.2$$

$$\Rightarrow R + 1 = 30 \Rightarrow R = 29 \Omega.$$

18.  $V = \varepsilon + ir$

$$\Rightarrow 7.2 = 6 + 2 \times r$$

$$\Rightarrow 1.2 = 2r \Rightarrow r = 0.6 \Omega.$$

19. a) net emf while charging

$$9 - 6 = 3\text{V}$$

$$\text{Current} = 3/10 = 0.3 \text{ A}$$

- b) When completely charged.

$$\text{Internal resistance 'r' } = 1 \Omega$$

$$\text{Current} = 3/1 = 3 \text{ A}$$

20. a)  $0.1i_1 + 1 i_1 - 6 + 1i_1 - 6 = 0$

$$\Rightarrow 0.1 i_1 + 1i_1 + 1i_1 = 12$$

$$\Rightarrow i_1 = \frac{12}{2.1}$$

ABCD

$$\Rightarrow 0.1i_2 + 1i_1 - 6 = 0$$

$$\Rightarrow 0.1i_2 + 1i_1$$

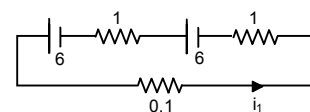
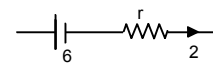
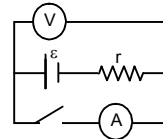

ADEFA,

$$\begin{aligned} \Rightarrow i - 6 + 6 - (i_2 - i)1 &= 0 \\ \Rightarrow i - i_2 + i &= 0 \\ \Rightarrow 2i - i_2 = 0 \Rightarrow -2i \pm 0.2i &= 0 \\ \Rightarrow i_2 &= 0. \end{aligned}$$

b)  $1i_1 + 1i_1 - 6 + 1i_1 = 0$   
 $\Rightarrow 3i_1 = 12 \Rightarrow i_1 = 4$

DCFED

$$\Rightarrow i_2 + i - 6 = 0 \Rightarrow i_2 + i = 6$$

ABCD,

$$\begin{aligned} i_2 + (i_2 - i) - 6 &= 0 \\ \Rightarrow i_2 + i_2 - i &= 6 \Rightarrow 2i_2 - i = 6 \\ \Rightarrow -2i_2 \pm 2i &= 6 \Rightarrow i = -2 \\ i_2 + i &= 6 \\ \Rightarrow i_2 - 2 &= 6 \Rightarrow i_2 = 8 \\ \frac{i_1}{i_2} &= \frac{4}{8} = \frac{1}{2}. \end{aligned}$$

c)  $10i_1 + 1i_1 - 6 + 1i_1 - 6 = 0$   
 $\Rightarrow 12i_1 = 12 \Rightarrow i_1 = 1$   
 $10i_2 - i_1 - 6 = 0$   
 $\Rightarrow 10i_2 - i_1 = 6$   
 $\Rightarrow 10i_2 + (i_2 - i)1 - 6 = 0$   
 $\Rightarrow 11i_2 = 6$   
 $\Rightarrow -i_2 = 0$

21. a) Total emf =  $n_1E$   
 in 1 row

Total emf in all news =  $n_1E$   
 Total resistance in one row =  $n_1r$

Total resistance in all rows =  $\frac{n_1r}{n_2}$

Net resistance =  $\frac{n_1r}{n_2} + R$

Current =  $\frac{n_1E}{n_1/n_2r + R} = \frac{n_1n_2E}{n_1r + n_2R}$

b)  $I = \frac{n_1n_2E}{n_1r + n_2R}$

for I = max,

$$n_1r + n_2R = \min$$

$$\Rightarrow (\sqrt{n_1r} - \sqrt{n_2R})^2 + 2\sqrt{n_1n_2R} = \min$$

it is min, when

$$\sqrt{n_1r} = \sqrt{n_2R}$$

$$\Rightarrow n_1r = n_2R$$

I is max when  $n_1r = n_2R$ .

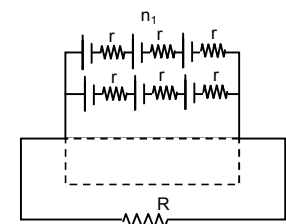
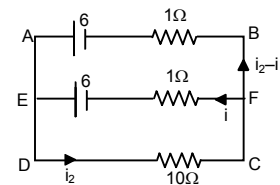
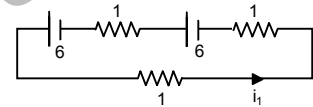
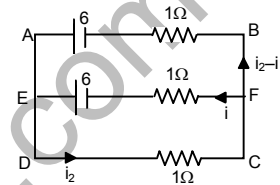
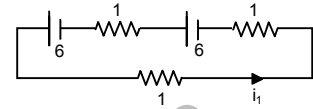
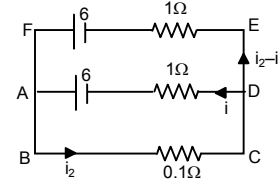

22.  $E = 100 \text{ V}$ ,  $R' = 100 \text{ k}\Omega = 100000 \Omega$

$R = 1 - 100$

When no other resistor is added or  $R = 0$ .

$$i = \frac{E}{R'} = \frac{100}{100000} = 0.001 \text{ Amp}$$

When  $R = 1$

$$i = \frac{100}{100000 + 1} = \frac{100}{100001} = 0.0009 \text{ A}$$

When  $R = 100$

$$i = \frac{100}{100000 + 100} = \frac{100}{100100} = 0.000999 \text{ A}$$

Upto  $R = 100$  the current does not upto 2 significant digits. Thus it proved.

23.  $A_1 = 2.4 \text{ A}$

Since  $A_1$  and  $A_2$  are in parallel,

$$\Rightarrow 20 \times 2.4 = 30 \times X$$

$$\Rightarrow X = \frac{20 \times 2.4}{30} = 1.6 \text{ A}$$

Reading in Ammeter  $A_2$  is  $1.6 \text{ A}$ .

$$A_3 = A_1 + A_2 = 2.4 + 1.6 = 4.0 \text{ A}$$

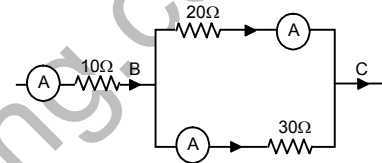

24.

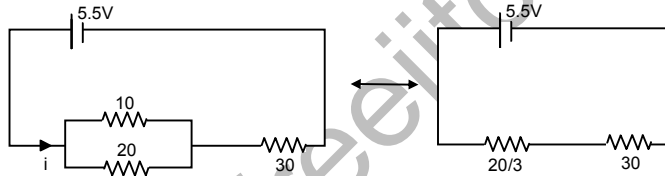
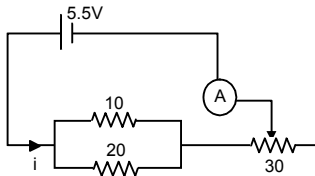

$$i_{\min} = \frac{5.5 \times 3}{110} = 0.15$$

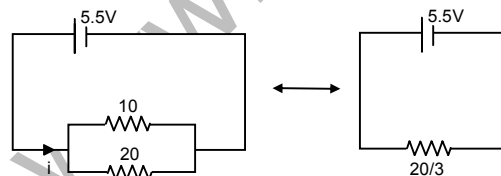

$$i_{\max} = \frac{5.5 \times 3}{20} = \frac{16.5}{20} = 0.825$$

25. a)  $R_{\text{eff}} = \frac{180}{3} = 60 \Omega$

$$i = 60 / 60 = 1 \text{ A}$$

b)  $R_{\text{eff}} = \frac{180}{2} = 90 \Omega$

$$i = 60 / 90 = 0.67 \text{ A}$$

c)  $R_{\text{eff}} = 180 \Omega \Rightarrow i = 60 / 180 = 0.33 \text{ A}$

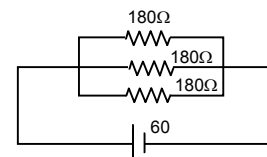

26. Max.  $R = (20 + 50 + 100) \Omega = 170 \Omega$

$$\text{Min } R = \frac{1}{\left(\frac{1}{20} + \frac{1}{50} + \frac{1}{100}\right)} = \frac{100}{8} = 12.5 \Omega.$$

27. The various resistances of the bulbs =  $\frac{V^2}{P}$

$$\text{Resistances are } \frac{(15)^2}{10}, \frac{(15)^2}{10}, \frac{(15)^2}{15} = 45, 22.5, 15.$$

Since two resistances when used in parallel have resistances less than both.

The resistances are 45 and 22.5.

28.  $i_1 \times 20 = i_2 \times 10$

$$\Rightarrow \frac{i_1}{i_2} = \frac{10}{20} = \frac{1}{2}$$

$$i_1 = 4 \text{ mA}, i_2 = 8 \text{ mA}$$

Current in  $20 \text{ K}\Omega$  resistor = 4 mA

Current in  $10 \text{ K}\Omega$  resistor = 8 mA

Current in  $100 \text{ K}\Omega$  resistor = 12 mA

$$V = V_1 + V_2 + V_3$$

$$= 5 \text{ K}\Omega \times 12 \text{ mA} + 10 \text{ K}\Omega \times 8 \text{ mA} + 100 \text{ K}\Omega \times 12 \text{ mA}$$

$$= 60 + 80 + 1200 = 1340 \text{ volts.}$$

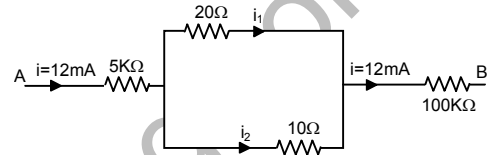

29.  $R_1 = R, i_1 = 5 \text{ A}$

$$R_2 = \frac{10R}{10+R}, i_2 = 6 \text{ A}$$

Since potential constant,

$$i_1 R_1 = i_2 R_2$$

$$\Rightarrow 5 \times R = \frac{6 \times 10R}{10+R}$$

$$\Rightarrow (10 + R)5 = 60$$

$$\Rightarrow 5R = 10 \Rightarrow R = 2 \Omega.$$

30.

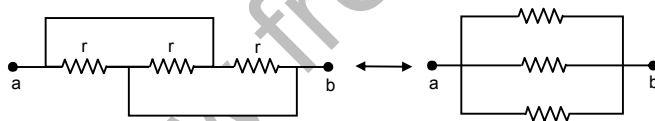

Eq. Resistance =  $r/3$ .

31. a)  $R_{\text{eff}} = \frac{\frac{15 \times 5}{6} \times \frac{15}{6}}{\frac{15 \times 5}{6} + \frac{15}{6}} = \frac{\frac{15 \times 5 \times 15}{6 \times 6}}{\frac{75 + 15}{6}} = \frac{15 \times 5 \times 15}{6 \times 90} = \frac{25}{12} = 2.08 \Omega.$

b) Across AC,

$$R_{\text{eff}} = \frac{\frac{15 \times 4}{6} \times \frac{15 \times 2}{6}}{\frac{15 \times 4}{6} + \frac{15 \times 2}{6}} = \frac{\frac{15 \times 4 \times 15 \times 2}{6 \times 6}}{\frac{60 + 30}{6}} = \frac{15 \times 4 \times 15 \times 2}{6 \times 90} = \frac{10}{3} = 3.33 \Omega.$$

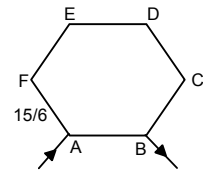

c) Across AD,

$$R_{\text{eff}} = \frac{\frac{15 \times 3}{6} \times \frac{15 \times 3}{6}}{\frac{15 \times 3}{6} + \frac{15 \times 3}{6}} = \frac{15 \times 3 \times 15 \times 3}{60 + 30}$$

$$= \frac{15 \times 3 \times 15 \times 3}{6 \times 90} = \frac{15}{4} = 3.75 \Omega.$$

32. a) When S is open

$$R_{\text{eq}} = (10 + 20) \Omega = 30 \Omega.$$

i = When S is closed,

$$R_{\text{eq}} = 10 \Omega$$

$$i = (3/10) \Omega = 0.3 \Omega.$$

33. a) Current through (1) 4 Ω resistor = 0

b) Current through (2) and (3)

$$\text{net } E = 4V - 2V = 2V$$

(2) and (3) are in series,

$$R_{\text{eff}} = 4 + 6 = 10 \Omega$$

$$i = 2/10 = 0.2 \text{ A}$$

Current through (2) and (3) are 0.2 A.

34. Let potential at the point be xV.

$$(30 - x) = 10 i_1$$

$$(x - 12) = 20 i_2$$

$$(x - 2) = 30 i_3$$

$$i_1 = i_2 + i_3$$

$$\Rightarrow \frac{30 - x}{10} = \frac{x - 12}{20} + \frac{x - 2}{30}$$

$$\Rightarrow 30 - x = \frac{x - 12}{2} + \frac{x - 2}{3}$$

$$\Rightarrow 30 - x = \frac{3x - 36 + 2x - 4}{6}$$

$$\Rightarrow 180 - 6x = 5x - 40$$

$$\Rightarrow 11x = 220 \Rightarrow x = 220 / 11 = 20 \text{ V.}$$

$$i_1 = \frac{30 - 20}{10} = 1 \text{ A}$$

$$i_2 = \frac{20 - 12}{20} = 0.4 \text{ A}$$

$$i_3 = \frac{20 - 2}{30} = \frac{6}{10} = 0.6 \text{ A.}$$

35. a) Potential difference between terminals of 'a' is 10 V.

$$i \text{ through } a = 10 / 10 = 1 \text{ A}$$

Potential different between terminals of b is 10 - 10 = 0 V

$$i \text{ through } b = 0/10 = 0 \text{ A}$$

b) Potential difference across 'a' is 10 V

$$i \text{ through } a = 10 / 10 = 1 \text{ A}$$

Potential different between terminals of b is 10 - 10 = 0 V

$$i \text{ through } b = 0/10 = 0 \text{ A}$$

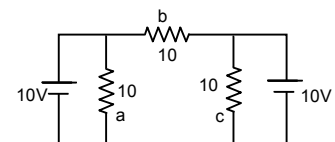
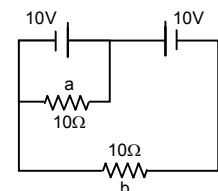
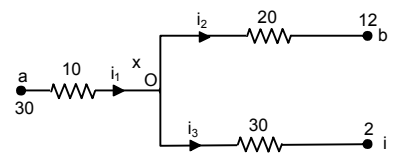
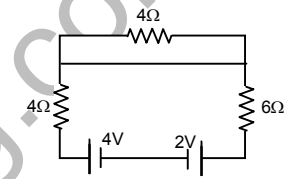
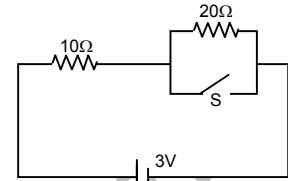



36. a) In circuit, AB ba A

$$E_2 + iR_2 + i_1R_3 = 0$$

In circuit,  $i_1R_3 + E_1 - (i - i_1)R_1 = 0$

$$\Rightarrow i_1R_3 + E_1 - iR_1 + i_1R_1 = 0$$

$$[iR_2 + i_1R_3 = -E_2]R_1$$

$$[iR_2 - i_1(R_1 + R_3) = E_1] R_2$$

$$iR_2R_1 + i_1R_3R_1 = -E_2R_1$$

$$iR_2R_1 - i_1R_2(R_1 + R_3) = E_1 R_2$$

$$iR_3R_1 + i_1R_2R_1 + i_1R_2R_3 = E_1R_2 - E_2R_1$$

$$\Rightarrow i_1(R_3R_1 + R_2R_1 + R_2R_3) = E_1R_2 - E_2R_1$$

$$\Rightarrow i_1 = \frac{E_1R_2 - E_2R_1}{R_3R_1 + R_2R_1 + R_2R_3}$$

$$\Rightarrow \frac{E_1R_2R_3 - E_2R_1R_3}{R_3R_1 + R_2R_1 + R_2R_3} = \left( \frac{E_1 - E_2}{\frac{1}{R_2} + \frac{1}{R_1} + \frac{1}{R_3}} \right)$$

b)  $\therefore$  Same as a

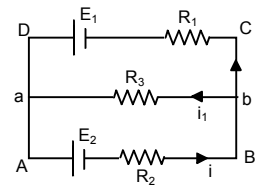
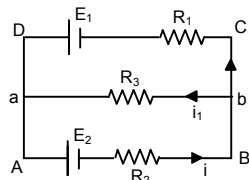
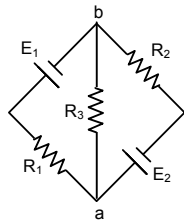

37. In circuit ABDCA,

$$i_1 + 2 - 3 + i = 0$$

$$\Rightarrow i + i_1 - 1 = 0 \quad \dots(1)$$

In circuit CFEDC,

$$(i - i_1) + 1 - 3 + i = 0$$

$$\Rightarrow 2i - i_1 - 2 = 0 \quad \dots(2)$$

From (1) and (2)

$$3i = 3 \Rightarrow i = 1 \text{ A}$$

$$i_1 = 1 - i = 0 \text{ A}$$

$$i - i_1 = 1 - 0 = 1 \text{ A}$$

Potential difference between A and B

$$= E - ir = 3 - 1.1 = 2 \text{ V.}$$

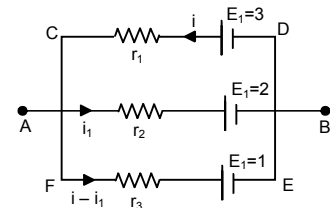

38. In the circuit ADCBA,

$$3i + 6i_1 - 4.5 = 0$$

In the circuit GEFCG,

$$3i + 6i_1 = 4.5 \quad = \quad 10i - 10i_1 - 6i_1 = -3$$

$$\Rightarrow [10i - 16i_1 = -3]3 \quad \dots(1)$$

$$[3i + 6i_1 = 4.5] 10 \quad \dots(2)$$

From (1) and (2)

$$-108 i_1 = -54$$

$$\Rightarrow i_1 = \frac{54}{108} = \frac{1}{2} = 0.5$$

$$3i + 6 \times \frac{1}{2} - 4.5 = 0$$

$$3i - 1.5 = 0 \Rightarrow i = 0.5.$$

Current through  $10 \Omega$  resistor = 0 A.

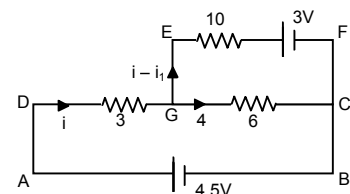

39. In AHGBA,

$$2 + (i - i_1) - 2 = 0$$

$$\Rightarrow i - i_1 = 0$$

In circuit CFEDC,

$$-(i_1 - i_2) + 2 + i_2 - 2 = 0$$

$$\Rightarrow i_2 - i_1 + i_2 = 0 \Rightarrow 2i_2 - i_1 = 0.$$

In circuit BGFCEB,

$$-(i_1 - i_2) + 2 + (i_1 - i_2) - 2 = 0$$

$$\Rightarrow i_1 - i + i_1 - i_2 = 0 \quad \Rightarrow 2i_1 - i - i_2 = 0 \quad \dots(1)$$

$$\Rightarrow i_1 - (i - i_1) - i_2 = 0 \quad \Rightarrow i_1 - i_2 = 0 \quad \dots(2)$$

$$\therefore i_1 - i_2 = 0$$

From (1) and (2)

Current in the three resistors is 0.

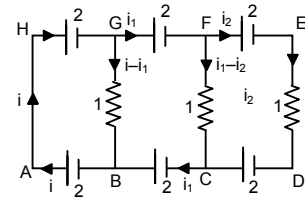

40.

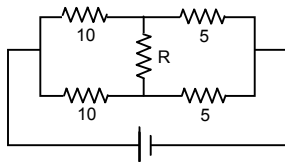

For an value of R, the current in the branch is 0.

41. a)  $R_{\text{eff}} = \frac{(2r/2) \times r}{(2r/2) + r}$   
 $= \frac{r^2}{2r} = \frac{r}{2}$

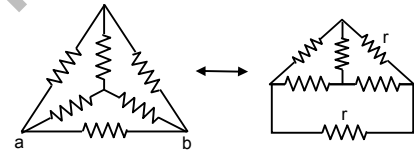

b) At 0 current coming to the junction is current going from BO = Current going along OE.

Current on CO = Current on OD

Thus it can be assumed that current coming in OC goes in OB.

Thus the figure becomes

$$\left[ r + \left( \frac{2r \cdot r}{3r} \right) + r \right] = 2r + \frac{2r}{3} = \frac{8r}{3}$$

$$R_{\text{eff}} = \frac{(8r/6) \times 2r}{(8r/6) + 2r} = \frac{8r^2/3}{20r/6} = \frac{8r^2}{3} \times \frac{6}{20} = \frac{8r}{10} = 4r.$$

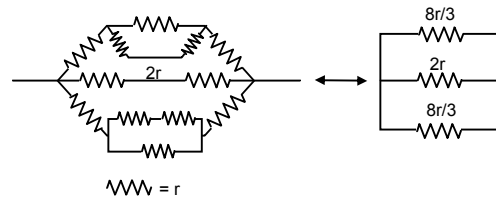
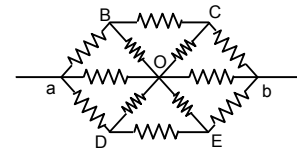

42.

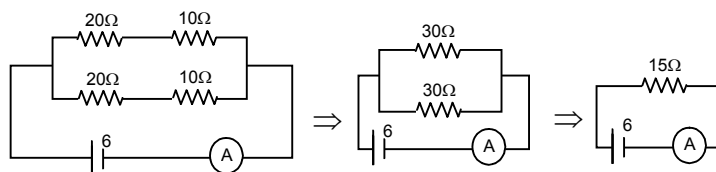
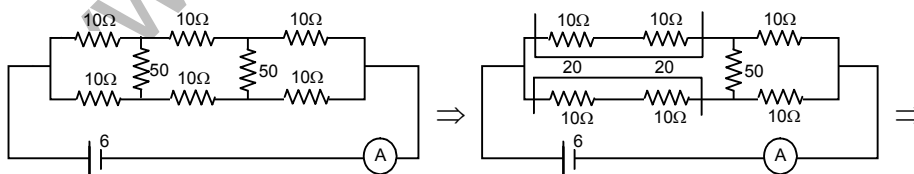

$$I = \frac{6}{15} = \frac{2}{5} = 0.4 \text{ A.}$$

43. a) Applying Kirchoff's law,

$$10i - 6 + 5i - 12 = 0$$

$$\Rightarrow 10i + 5i = 18$$

$$\Rightarrow 15i = 18$$

$$\Rightarrow i = \frac{18}{15} = \frac{6}{5} = 1.2 \text{ A.}$$

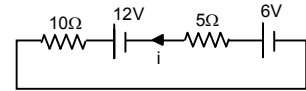

b) Potential drop across 5 Ω resistor,

$$i 5 = 1.2 \times 5 \text{ V} = 6 \text{ V}$$

c) Potential drop across 10 Ω resistor

$$i 10 = 1.2 \times 10 \text{ V} = 12 \text{ V}$$

d)  $10i - 6 + 5i - 12 = 0$

$$\Rightarrow 10i + 5i = 18$$

$$\Rightarrow 15i = 18$$

$$\Rightarrow i = \frac{18}{15} = \frac{6}{5} = 1.2 \text{ A.}$$



Potential drop across 5 Ω resistor = 6 V

Potential drop across 10 Ω resistor = 12 V

44. Taking circuit ABHGA,

$$\frac{i}{3r} + \frac{i}{6r} + \frac{i}{3r} = V$$

$$\Rightarrow \left(\frac{2i}{3} + \frac{i}{6}\right)r = V$$

$$\Rightarrow V = \frac{5i}{6}r$$

$$\Rightarrow R_{\text{eff}} = \frac{V}{i} = \frac{5}{6}r$$

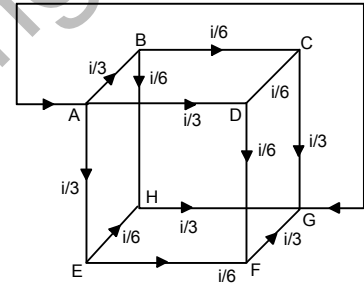

45.  $R_{\text{eff}} = \frac{\left(\frac{2r}{3} + r\right)r}{\left(\frac{2r}{3} + r + r\right)} = \frac{5r}{8}$

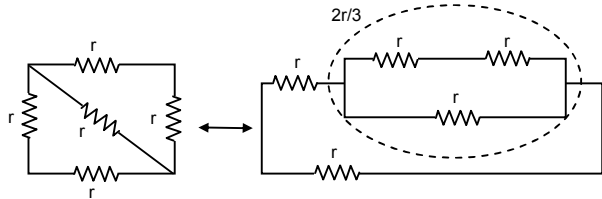

$$R_{\text{eff}} = \frac{r}{3} + r = \frac{4r}{3}$$

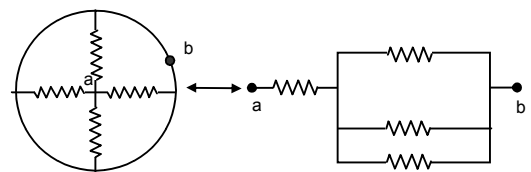

$$R_{\text{eff}} = \frac{2r}{2} = r$$

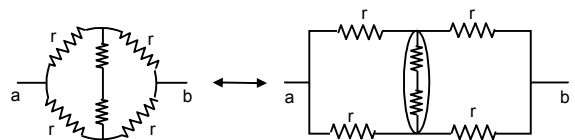

$$R_{\text{eff}} = \frac{r}{4}$$

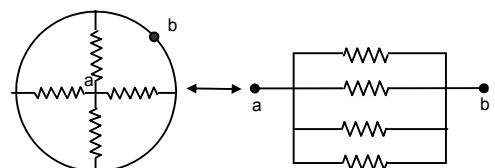

$$R_{\text{eff}} = r$$

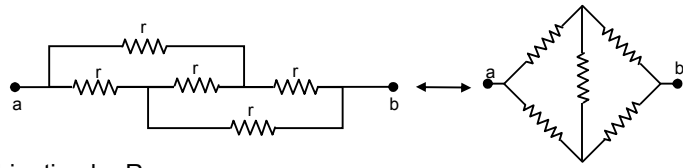

46. a) Let the equivalent resistance of the combination be R.

$$\left(\frac{2R}{R+2}\right) + 1 = R$$

$$\Rightarrow \frac{2R + R + 2}{R + 2} = R \Rightarrow 3R + 2 = R^2 + 2R$$

$$\Rightarrow R^2 - R - 2 = 0$$

$$\Rightarrow R = \frac{+1 \pm \sqrt{1 + 4 \cdot 1 \cdot 2}}{2 \cdot 1} = \frac{1 \pm \sqrt{9}}{2} = \frac{1 + 3}{2} = 2 \Omega.$$

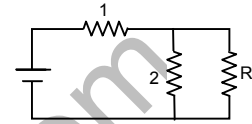
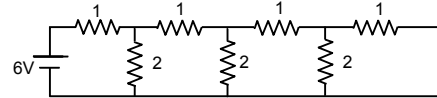

b) Total current sent by battery =  $\frac{6}{R_{\text{eff}}} = \frac{6}{2} = 3$

Potential between A and B

$$3 \cdot 1 + 2 \cdot i = 6$$

$$\Rightarrow 3 + 2i = 6 \Rightarrow 2i = 3$$

$$\Rightarrow i = 1.5 \text{ a}$$

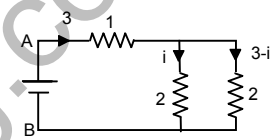

47. a) In circuit ABFGA,

$$i_1 \cdot 50 + 2i + i - 4.3 = 0$$

$$\Rightarrow 50i_1 + 3i = 4.3 \quad \dots(1)$$

In circuit BEDCB,

$$50i_1 - (i - i_1)200 = 0$$

$$\Rightarrow 50i_1 - 200i + 200i_1 = 0$$

$$\Rightarrow 250i_1 - 200i = 0$$

$$\Rightarrow 50i_1 - 40i = 0 \quad \dots(2)$$

From (1) and (2)

$$43i = 4.3 \quad \Rightarrow i = 0.1$$

$$5i_1 = 4 \times i = 4 \times 0.1 \quad \Rightarrow i_1 = \frac{4 \times 0.1}{5} = 0.08 \text{ A.}$$

Ammeter reads a current =  $i = 0.1 \text{ A.}$

Voltmeter reads a potential difference equal to  $i_1 \times 50 = 0.08 \times 50 = 4 \text{ V.}$

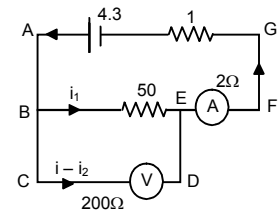

- b) In circuit ABEFA,

$$50i_1 + 2i_1 + i - 4.3 = 0$$

$$\Rightarrow 52i_1 + i = 4.3$$

$$\Rightarrow 200 \times 52i_1 + 200i = 4.3 \times 200 \quad \dots(1)$$

In circuit BCDEB,

$$(i - i_1)200 - i_1 \cdot 2 - i_1 \cdot 50 = 0$$

$$\Rightarrow 200i - 200i_1 - 2i_1 - 50i_1 = 0$$

$$\Rightarrow 200i - 252i_1 = 0 \quad \dots(2)$$

From (1) and (2)

$$i_1(10652) = 4.3 \times 2 \times 100$$

$$\Rightarrow i_1 = \frac{4.3 \times 2 \times 100}{10652} = 0.08$$

$$i = 4.3 - 52 \times 0.08 = 0.14$$

Reading of the ammeter =  $0.08 \text{ a}$

Reading of the voltmeter =  $(i - i_1)200 = (0.14 - 0.08) \times 200 = 12 \text{ V.}$

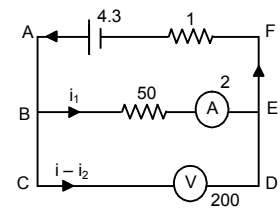

48. a)  $R_{\text{eff}} = \frac{100 \times 400}{500} + 200 = 280$

$i = \frac{84}{280} = 0.3$

$100i = (0.3 - i) 400$

$\Rightarrow i = 1.2 - 4i$

$\Rightarrow 5i = 1.2 \Rightarrow i = 0.24.$

Voltage measured by the voltmeter =  $\frac{0.24 \times 100}{24V}$

b) If voltmeter is not connected

$R_{\text{eff}} = (200 + 100) = 300 \Omega$

$i = \frac{84}{300} = 0.28 \text{ A}$

Voltage across  $100 \Omega = (0.28 \times 100) = 28 \text{ V}.$

49. Let resistance of the voltmeter be  $R \Omega.$

$R_1 = \frac{50R}{50 + R}, R_2 = 24$

Both are in series.

$30 = V_1 + V_2$

$\Rightarrow 30 = iR_1 + iR_2$

$\Rightarrow 30 - iR_2 = iR_1$

$\Rightarrow iR_1 = 30 - \frac{30}{R_1 + R_2} R_2$

$\Rightarrow V_1 = 30 \left( 1 - \frac{R_2}{R_1 + R_2} \right)$

$\Rightarrow V_1 = 30 \left( \frac{R_1}{R_1 + R_2} \right)$

$\Rightarrow 18 = 30 \left( \frac{50R}{50 + R \left( \frac{50R}{50 + R} + 24 \right)} \right)$

$\Rightarrow 18 = 30 \left( \frac{50R \times (50 + R)}{(50 + R) + (50R + 24)(50 + R)} \right) = \frac{30(50R)}{50R + 1200 + 24R}$

$\Rightarrow 18 = \frac{30 \times 50 \times R}{74R + 1200} = 18(74R + 1200) = 1500 R$

$\Rightarrow 1332R + 21600 = 1500 R \Rightarrow 21600 = 1.68 R$

$\Rightarrow R = 21600 / 168 = 128.57.$

50. Full deflection current =  $10 \text{ mA} = (10 \times 10^{-3}) \text{ A}$

$R_{\text{eff}} = (575 + 25) \Omega = 600 \Omega$

$V = R_{\text{eff}} \times i = 600 \times 10 \times 10^{-3} = 6 \text{ V}.$

51.  $G = 25 \Omega, I_g = 1 \text{ ma}, I = 2 \text{ A}, S = ?$

Potential across A B is same

$25 \times 10^{-3} = (2 - 10^{-3}) S$

$\Rightarrow S = \frac{25 \times 10^{-3}}{2 - 10^{-3}} = \frac{25 \times 10^{-3}}{1.999}$

$= 12.5 \times 10^{-3} = 1.25 \times 10^{-2}.$

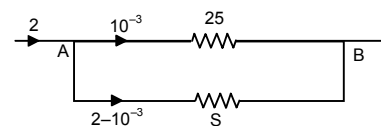
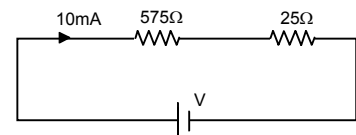
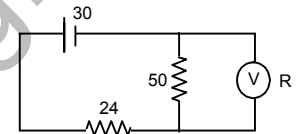
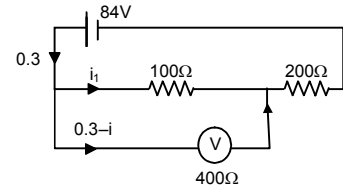

52.  $R_{\text{eff}} = (1150 + 50)\Omega = 1200 \Omega$

$i = (12 / 1200)\text{A} = 0.01 \text{ A.}$

(The resistor of  $50 \Omega$  can tolerate)

Let  $R$  be the resistance of sheet used.

The potential across both the resistors is same.

$0.01 \times 50 = 1.99 \times R$

$\Rightarrow R = \frac{0.01 \times 50}{1.99} = \frac{50}{199} = 0.251 \Omega.$

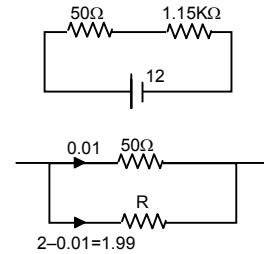

53. If the wire is connected to the potentiometer wire so that  $\frac{R_{AD}}{R_{DB}} = \frac{8}{12}$ , then according to wheat stone's

bridge no current will flow through galvanometer.

$\frac{R_{AB}}{R_{DB}} = \frac{L_{AB}}{L_B} = \frac{8}{12} = \frac{2}{3}$  (Acc. To principle of potentiometer).

$I_{AB} + I_{DB} = 40 \text{ cm}$

$\Rightarrow I_{DB} \frac{2}{3} + I_{DB} = 40 \text{ cm}$

$\Rightarrow (\frac{2}{3} + 1)I_{DB} = 40 \text{ cm}$

$\Rightarrow \frac{5}{3} I_{DB} = 40 \Rightarrow L_{DB} = \frac{40 \times 3}{5} = 24 \text{ cm.}$

$L_{AB} = (40 - 24) \text{ cm} = 16 \text{ cm.}$

54. The deflections does not occur in galvanometer if the condition is a balanced wheatstone bridge.

Let Resistance / unit length =  $r.$

Resistance of 30 m length =  $30r.$

Resistance of 20 m length =  $20r.$

For balanced wheatstones bridge =  $\frac{6}{R} = \frac{30r}{20r}$

$\Rightarrow 30R = 20 \times 6 \Rightarrow R = \frac{20 \times 6}{30} = 4 \Omega.$

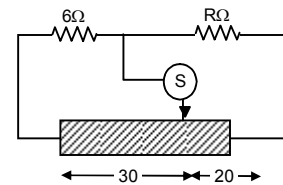
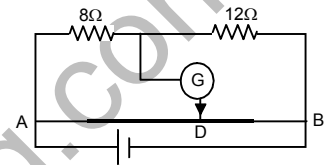

55. a) Potential difference between A and B is 6 V.

B is at 0 potential.

Thus potential of A point is 6 V.

The potential difference between Ac is 4 V.

$V_A - V_C = 0.4$

$V_C = V_A - 4 = 6 - 4 = 2 \text{ V.}$

b) The potential at D = 2V,  $V_{AD} = 4 \text{ V}; V_{BD} = 0\text{V}$

Current through the resistors  $R_1$  and  $R_2$  are equal.

Thus,  $\frac{4}{R_1} = \frac{2}{R_2}$

$\Rightarrow \frac{R_1}{R_2} = 2$

$\Rightarrow \frac{l_1}{l_2} = 2$  (Acc. to the law of potentiometer)

$l_1 + l_2 = 100 \text{ cm}$

$\Rightarrow l_1 + \frac{l_1}{2} = 100 \text{ cm} \Rightarrow \frac{3l_1}{2} = 100 \text{ cm}$

$\Rightarrow l_1 = \frac{200}{3} \text{ cm} = 66.67 \text{ cm.}$

$AD = 66.67 \text{ cm}$

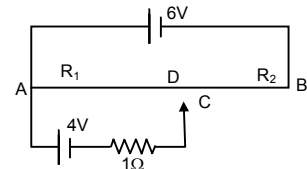

- c) When the points C and D are connected by a wire current flowing through it is 0 since the points are equipotential.  
 d) Potential at A = 6 v  
 Potential at C = 6 - 7.5 = -1.5 V  
 The potential at B = 0 and towards A potential increases.  
 Thus -ve potential point does not come within the wire.

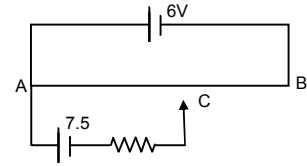

56. Resistance per unit length =  $\frac{15r}{6}$

For length x,  $R_x = \frac{15r}{6} \times x$

a) For the loop PASQ  $(i_1 + i_2) \frac{15}{6} rx + \frac{15}{6} (6 - x)i_1 + i_1 R = E \dots(1)$

For the loop AWTM,  $-i_2 \cdot R - \frac{15}{6} rx (i_1 + i_2) = E/2$

$\Rightarrow i_2 R + \frac{15}{6} r \times (i_1 + i_2) = E/2 \dots(2)$

For zero deflection galvanometer  $i_2 = 0 \Rightarrow \frac{15}{6} rx \cdot i_1 = E/2 = i_1 = \frac{E}{5x \cdot r}$

Putting  $i_1 = \frac{E}{5x \cdot r}$  and  $i_2 = 0$  in equation (1), we get  $x = 320$  cm.

b) Putting  $x = 5.6$  and solving equation (1) and (2) we get  $i_2 = \frac{3E}{22r}$ .

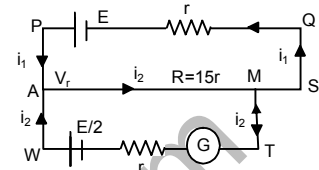

57. In steady stage condition no current flows through the capacitor.

$R_{\text{eff}} = 10 + 20 = 30 \Omega$

$i = \frac{2}{30} = \frac{1}{15} \text{ A}$

Voltage drop across 10  $\Omega$  resistor =  $i \times R$

$= \frac{1}{15} \times 10 = \frac{10}{15} = \frac{2}{3} \text{ V}$

Charge stored on the capacitor (Q) = CV

$= 6 \times 10^{-6} \times 2/3 = 4 \times 10^{-6} \text{ C} = 4 \mu\text{C}$ .

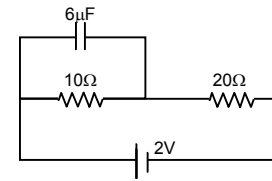

58. Taking circuit, ABCDA,

$10i + 20(i - i_1) - 5 = 0$

$\Rightarrow 10i + 20i - 20i_1 - 5 = 0$

$\Rightarrow 30i - 20i_1 - 5 = 0 \dots(1)$

Taking circuit ABFEA,

$20(i - i_1) - 5 - 10i_1 = 0$

$\Rightarrow 10i - 20i_1 - 10i_1 - 5 = 0$

$\Rightarrow 20i - 30i_1 - 5 = 0 \dots(2)$

From (1) and (2)

$(90 - 40)i_1 = 0$

$\Rightarrow i_1 = 0$

$30i - 5 = 0$

$\Rightarrow i = 5/30 = 0.16 \text{ A}$

Current through 20  $\Omega$  is 0.16 A.

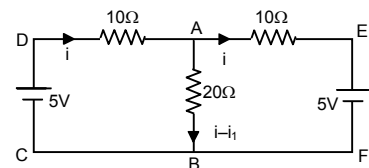

59. At steady state no current flows through the capacitor.

$$R_{eq} = \frac{3 \times 6}{3 + 6} = 2 \Omega.$$

$$i = \frac{6}{2} = 3.$$

Since current is divided in the inverse ratio of the resistance in each branch, thus  $2\Omega$  will pass through 1,  $2 \Omega$  branch and 1 through 3,  $3\Omega$  branch

$$V_{AB} = 2 \times 1 = 2V.$$

$$Q \text{ on } 1 \mu F \text{ capacitor} = 2 \times 1 \mu C = 2 \mu C$$

$$V_{BC} = 2 \times 2 = 4V.$$

$$Q \text{ on } 2 \mu F \text{ capacitor} = 4 \times 2 \mu C = 8 \mu C$$

$$V_{DE} = 1 \times 3 = 2V.$$

$$Q \text{ on } 4 \mu F \text{ capacitor} = 3 \times 4 \mu C = 12 \mu C$$

$$V_{FE} = 3 \times 1 = V.$$

$$Q \text{ across } 3 \mu F \text{ capacitor} = 3 \times 3 \mu C = 9 \mu C.$$

60.  $C_{eq} = [(3 \mu f \text{ p } 3 \mu f) \text{ s } (1 \mu f \text{ p } 1 \mu f)] \text{ p } (1 \mu f)$   
 $= [(3 + 3)\mu f \text{ s } (2\mu f)] \text{ p } 1 \mu f$   
 $= 3/2 + 1 = 5/2 \mu f$

$$V = 100 \text{ V}$$

$$Q = CV = 5/2 \times 100 = 250 \mu C$$

$$\text{Charge stored across } 1 \mu f \text{ capacitor} = 100 \mu C$$

$$C_{eq} \text{ between A and B is } 6 \mu f = C$$

$$\text{Potential drop across AB} = V = Q/C = 25 \text{ V}$$

$$\text{Potential drop across BC} = 75 \text{ V.}$$

61. a) Potential difference = E across resistor  
 b) Current in the circuit =  $E/R$   
 c) Pd. Across capacitor =  $E/R$

$$d) \text{ Energy stored in capacitor} = \frac{1}{2} CE^2$$

$$e) \text{ Power delivered by battery} = E \times I = E \times \frac{E}{R} = \frac{E^2}{R}$$

$$f) \text{ Power converted to heat} = \frac{E^2}{R}$$

62.  $A = 20 \text{ cm}^2 = 20 \times 10^{-4} \text{ m}^2$   
 $d = 1 \text{ mm} = 1 \times 10^{-3} \text{ m}$ ;  $R = 10 \text{ K}\Omega$

$$C = \frac{\epsilon_0 A}{d} = \frac{8.85 \times 10^{-12} \times 20 \times 10^{-4}}{1 \times 10^{-3}}$$

$$= \frac{8.85 \times 10^{-12} \times 2 \times 10^{-3}}{10^{-3}} = 17.7 \times 10^{-2} \text{ Farad.}$$

$$\text{Time constant} = CR = 17.7 \times 10^{-2} \times 10 \times 10^3$$

$$= 17.7 \times 10^{-8} = 0.177 \times 10^{-6} \text{ s} = 0.18 \mu s.$$

63.  $C = 10 \mu F = 10^{-5} \text{ F}$ ,  $\text{emf} = 2 \text{ V}$   
 $t = 50 \text{ ms} = 5 \times 10^{-2} \text{ s}$ ,  $q = Q(1 - e^{-t/RC})$   
 $Q = CV = 10^{-5} \times 2$   
 $q = 12.6 \times 10^{-6} \text{ F}$   
 $\Rightarrow 12.6 \times 10^{-6} = 2 \times 10^{-5} (1 - e^{-5 \times 10^{-2} / R \times 10^{-5}})$

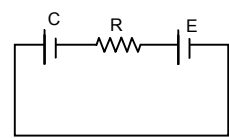
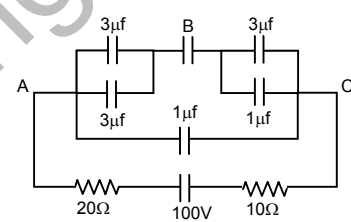
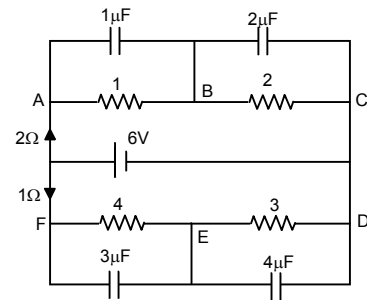



$$\Rightarrow \frac{12.6 \times 10^{-6}}{2 \times 10^{-5}} = 1 - e^{-5 \times 10^{-2} / R \times 10^{-5}}$$

$$\Rightarrow 1 - 0.63 = e^{-5 \times 10^3 / R}$$

$$\Rightarrow \frac{-5000}{R} = \ln 0.37$$

$$\Rightarrow R = \frac{5000}{0.9942} = 5028 \Omega = 5.028 \times 10^3 \Omega = 5 \text{ K}\Omega.$$

64.  $C = 20 \times 10^{-6} \text{ F}$ ,  $E = 6 \text{ V}$ ,  $R = 100 \Omega$

$$t = 2 \times 10^{-3} \text{ sec}$$

$$q = EC(1 - e^{-t/RC})$$

$$= 6 \times 20 \times 10^{-6} \left(1 - e^{-\frac{2 \times 10^{-3}}{100 \times 20 \times 10^{-6}}}\right)$$

$$= 12 \times 10^{-5} (1 - e^{-1}) = 7.12 \times 0.63 \times 10^{-5} = 7.56 \times 10^{-5}$$

$$= 75.6 \times 10^{-6} = 76 \mu\text{c}.$$

65.  $C = 10 \mu\text{F}$ ,  $Q = 60 \mu\text{C}$ ,  $R = 10 \Omega$

a) at  $t = 0$ ,  $q = 60 \mu\text{c}$

b) at  $t = 30 \mu\text{s}$ ,  $q = Qe^{-t/RC}$   
 $= 60 \times 10^{-6} \times e^{-0.3} = 44 \mu\text{c}$

c) at  $t = 120 \mu\text{s}$ ,  $q = 60 \times 10^{-6} \times e^{-1.2} = 18 \mu\text{c}$

d) at  $t = 1.0 \text{ ms}$ ,  $q = 60 \times 10^{-6} \times e^{-10} = 0.00272 = 0.003 \mu\text{c}.$

66.  $C = 8 \mu\text{F}$ ,  $E = 6\text{V}$ ,  $R = 24 \Omega$

a)  $I = \frac{V}{R} = \frac{6}{24} = 0.25\text{A}$

b)  $q = Q(1 - e^{-t/RC})$   
 $= (8 \times 10^{-6} \times 6) [1 - e^{-1}] = 48 \times 10^{-6} \times 0.63 = 3.024 \times 10^{-5}$

$$V = \frac{Q}{C} = \frac{3.024 \times 10^{-5}}{8 \times 10^{-6}} = 3.78$$

$$E = V + iR$$

$$\Rightarrow 6 = 3.78 + i24$$

$$\Rightarrow i = 0.09 \text{ A}$$

67.  $A = 40 \text{ m}^2 = 40 \times 10^{-4}$

$$d = 0.1 \text{ mm} = 1 \times 10^{-4} \text{ m}$$

$$R = 16 \Omega ; \text{emf} = 2 \text{ V}$$

$$C = \frac{E_0 A}{d} = \frac{8.85 \times 10^{-12} \times 40 \times 10^{-4}}{1 \times 10^{-4}} = 35.4 \times 10^{-11} \text{ F}$$

$$\text{Now, } E = \frac{Q}{AE_0} (1 - e^{-t/RC}) = \frac{CV}{AE_0} (1 - e^{-t/RC})$$

$$= \frac{35.4 \times 10^{-11} \times 2}{40 \times 10^{-4} \times 8.85 \times 10^{-12}} (1 - e^{-1.76})$$

$$= 1.655 \times 10^{-4} = 1.7 \times 10^{-4} \text{ V/m}.$$

68.  $A = 20 \text{ cm}^2$ ,  $d = 1 \text{ mm}$ ,  $K = 5$ ,  $e = 6 \text{ V}$

$$R = 100 \times 10^3 \Omega, t = 8.9 \times 10^{-5} \text{ s}$$

$$C = \frac{KE_0 A}{d} = \frac{5 \times 8.85 \times 10^{-12} \times 20 \times 10^{-4}}{1 \times 10^{-3}}$$

$$= \frac{10 \times 8.85 \times 10^{-3} \times 10^{-12}}{10^{-3}} = 88.5 \times 10^{-12}$$

$$q = EC(1 - e^{-t/RC})$$

$$= 6 \times 88.5 \times 10^{-12} \left( 1 - e^{\frac{-89 \times 10^{-6}}{88.5 \times 10^{-12} \times 10^4}} \right) = 530.97$$

$$\text{Energy} = \frac{1}{2} \times \frac{500.97 \times 530}{88.5 \times 10^{-12}}$$

$$= \frac{530.97 \times 530.97}{88.5 \times 2} \times 10^{12}$$

69. Time constant  $RC = 1 \times 10^6 \times 100 \times 10^6 = 100 \text{ sec}$

a)  $q = VC(1 - e^{-t/CR})$   
 $I = \text{Current} = dq/dt = VC \cdot (-) e^{-t/RC} \cdot (-1)/RC$   
 $= \frac{V}{R} e^{-t/RC} = \frac{V}{R \cdot e^{t/RC}} = \frac{24}{10^6} \cdot \frac{1}{e^{t/100}}$   
 $= 24 \times 10^{-6} \cdot 1/e^{t/100}$

$t = 10 \text{ min}, 600 \text{ sec.}$

$Q = 24 \times 10^{-6} \times (1 - e^{-6}) = 23.99 \times 10^{-4}$

$I = \frac{24}{10^6} \cdot \frac{1}{e^6} = 5.9 \times 10^{-8} \text{ Amp.}$

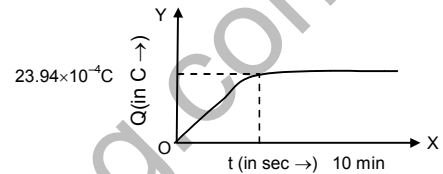
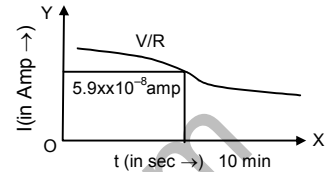

b)  $q = VC(1 - e^{-t/CR})$

70.  $Q/2 = Q(1 - e^{-t/CR})$

$\Rightarrow \frac{1}{2} = (1 - e^{-t/CR})$

$\Rightarrow e^{-t/CR} = 1/2$

$\Rightarrow \frac{t}{RC} = \log 2 \Rightarrow n = 0.69.$

71.  $q = Qe^{-t/RC}$

$q = 0.1 \% Q$        $RC \Rightarrow \text{Time constant}$   
 $= 1 \times 10^{-3} Q$

So,  $1 \times 10^{-3} Q = Q \times e^{-t/RC}$

$\Rightarrow e^{-t/RC} = 10^{-3}$

$\Rightarrow t/RC = -(-6.9) = 6.9$

72.  $q = Q(1 - e^{-t/RC})$

$\frac{1}{2} \frac{Q^2}{C} = \text{Initial value}; \frac{1}{2} \frac{q^2}{C} = \text{Final value}$

$\frac{1}{2} \frac{q^2}{C} \times 2 = \frac{1}{2} \frac{Q^2}{C}$

$\Rightarrow q^2 = \frac{Q^2}{2} \Rightarrow q = \frac{Q}{\sqrt{2}}$

$\frac{Q}{\sqrt{2}} = Q(1 - e^{-n})$

$\Rightarrow \frac{1}{\sqrt{2}} = 1 - e^{-n} \Rightarrow e^{-n} = 1 - \frac{1}{\sqrt{2}}$

$\Rightarrow n = \log \left( \frac{\sqrt{2}}{\sqrt{2}-1} \right) = 1.22$

73. Power =  $CV^2 = Q \times V$

Now,  $\frac{QV}{2} = QV \times e^{-t/RC}$

$$\Rightarrow \frac{1}{2} = e^{-t/RC}$$

$$\Rightarrow \frac{t}{RC} = -\ln 0.5$$

$$\Rightarrow -(-0.69) = 0.69$$

74. Let at any time  $t$ ,  $q = EC(1 - e^{-t/CR})$

$$E = \text{Energy stored} = \frac{q^2}{2c} = \frac{E^2 C^2}{2c} (1 - e^{-t/CR})^2 = \frac{E^2 C}{2} (1 - e^{-t/CR})^2$$

$$R = \text{rate of energy stored} = \frac{dE}{dt} = \frac{-E^2 C}{2} \left( \frac{-1}{RC} \right)^2 (1 - e^{-t/CR}) e^{-t/CR} = \frac{E^2}{CR} \cdot e^{-t/CR} (1 - e^{-t/CR})$$

$$\frac{dR}{dt} = \frac{E^2}{2R} \left[ \frac{-1}{RC} e^{-t/CR} \cdot (1 - e^{-t/CR}) + (-) \cdot e^{-t/CR(1-1/RC)} \cdot e^{-t/CR} \right]$$

$$\frac{E^2}{2R} = \left( \frac{-e^{-t/CR}}{RC} + \frac{e^{-2t/CR}}{RC} + \frac{1}{RC} \cdot e^{-2t/CR} \right) = \frac{E^2}{2R} \left( \frac{2}{RC} \cdot e^{-2t/CR} - \frac{e^{-t/CR}}{RC} \right) \dots(1)$$

$$\text{For } R_{\max} \frac{dR}{dt} = 0 \Rightarrow 2 \cdot e^{-t/RC} - 1 = 0 \Rightarrow e^{-t/RC} = 1/2$$

$$\Rightarrow -t/RC = -\ln 2 \Rightarrow t = RC \ln 2$$

$$\therefore \text{Putting } t = RC \ln 2 \text{ in equation (1) We get } \frac{dR}{dt} = \frac{E^2}{4R}$$

75.  $C = 12.0 \mu\text{F} = 12 \times 10^{-6}$

$$\text{emf} = 6.00 \text{ V}, R = 1 \Omega$$

$$t = 12 \mu\text{s}, i = i_0 e^{-t/RC}$$

$$= \frac{CV}{T} \times e^{-t/RC} = \frac{12 \times 10^{-6} \times 6}{12 \times 10^{-6}} \times e^{-1}$$

$$= 2.207 = 2.1 \text{ A}$$

b) Power delivered by battery

$$\text{We known, } V = V_0 e^{-t/RC} \quad (\text{where } V \text{ and } V_0 \text{ are potential VI})$$

$$VI = V_0 I e^{-t/RC}$$

$$\Rightarrow VI = V_0 I \times e^{-1} = 6 \times 6 \times e^{-1} = 13.24 \text{ W}$$

$$\text{c) } U = \frac{CV^2}{T} (e^{-t/RC})^2 \quad \left[ \frac{CV^2}{T} = \text{energy drawing per unit time} \right]$$

$$= \frac{12 \times 10^{-6} \times 36}{12 \times 10^{-6}} \times (e^{-1})^2 = 4.872$$

76. Energy stored at a part time in discharging =  $\frac{1}{2} CV^2 (e^{-t/RC})^2$

Heat dissipated at any time

$$= (\text{Energy stored at } t = 0) - (\text{Energy stored at time } t)$$

$$= \frac{1}{2} CV^2 - \frac{1}{2} CV^2 (e^{-1})^2 = \frac{1}{2} CV^2 (1 - e^{-2})$$

$$77. \int i^2 R dt = \int i_0^2 R e^{-2t/RC} dt = i_0^2 R \int e^{-2t/RC} dt$$

$$= i_0^2 R (-RC/2) e^{-2t/RC} = \frac{1}{2} C i_0^2 R^2 e^{-2t/RC} = \frac{1}{2} CV^2 \quad (\text{Proved}).$$

78. Equation of discharging capacitor

$$= q_0 e^{-t/RC} = \frac{K \epsilon_0 AV}{d} e^{-\frac{t}{(\rho d K \epsilon_0 A)/Ad}} = \frac{K \epsilon_0 AV}{d} e^{-t/\rho K \epsilon_0}$$

$$\therefore \tau = \rho K \epsilon_0$$

$\therefore$  Time constant is  $\rho K \epsilon_0$  is independent of plate area or separation between the plate.

79.  $q = q_0(1 - e^{-t/RC})$

$$= 25(2 + 2) \times 10^{-6} \left(1 - e^{\frac{-0.2 \times 10^{-3}}{25 \times 4 \times 10^{-6}}}\right)$$

$$= 24 \times 10^{-6} (1 - e^{-2}) = 20.75$$

Charge on each capacitor =  $20.75/2 = 10.3$

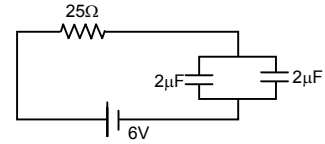

80. In steady state condition, no current passes through the 25 μF capacitor,

∴ Net resistance =  $\frac{10\Omega}{2} = 5\Omega$ .

Net current =  $\frac{12}{5}$

Potential difference across the capacitor = 5

Potential difference across the 10 Ω resistor

=  $12/5 \times 10 = 24$  V

$q = Q(e^{-t/RC}) = V \times C(e^{-t/RC}) = 24 \times 25 \times 10^{-6} [e^{-1 \times 10^{-3} / 10 \times 25 \times 10^{-4}}]$   
 =  $24 \times 25 \times 10^{-6} e^{-4} = 24 \times 25 \times 10^{-6} \times 0.0183 = 10.9 \times 10^{-6}$  C

Charge given by the capacitor after time t.

Current in the 10 Ω resistor =  $\frac{10.9 \times 10^{-6} \text{ C}}{1 \times 10^{-3} \text{ sec}} = 11 \text{ mA}$ .

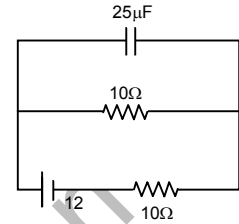

81.  $C = 100 \mu\text{F}$ ,  $\text{emf} = 6 \text{ V}$ ,  $R = 20 \text{ K}\Omega$ ,  $t = 4 \text{ S}$ .

Charging :  $Q = CV(1 - e^{-t/RC})$   $\left[\frac{-t}{RC} = \frac{4}{2 \times 10^4 \times 10^{-4}}\right]$

=  $6 \times 10^{-4} (1 - e^{-2}) = 5.187 \times 10^{-4} \text{ C} = Q$

Discharging :  $q = Q(e^{-t/RC}) = 5.184 \times 10^{-4} \times e^{-2}$   
 =  $0.7 \times 10^{-4} \text{ C} = 70 \mu\text{c}$ .

82.  $C_{\text{eff}} = \frac{C_1 C_2}{C_1 + C_2}$

$Q = C_{\text{eff}} E(1 - e^{-t/RC}) = \frac{C_1 C_2}{C_1 + C_2} E(1 - e^{-t/RC})$

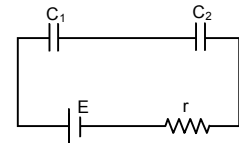

83. Let after time t charge on plate B is +Q.

Hence charge on plate A is Q - q.

$V_A = \frac{Q - q}{C}$ ,  $V_B = \frac{q}{C}$

$V_A - V_B = \frac{Q - q}{C} - \frac{q}{C} = \frac{Q - 2q}{C}$

Current =  $\frac{V_A - V_B}{R} = \frac{Q - 2q}{CR}$

Current =  $\frac{dq}{dt} = \frac{Q - 2q}{CR}$

$\Rightarrow \frac{dq}{Q - 2q} = \frac{1}{RC} \cdot dt \Rightarrow \int_0^q \frac{dq}{Q - 2q} = \frac{1}{RC} \cdot \int_0^t dt$

$\Rightarrow -\frac{1}{2} [\ln(Q - 2q) - \ln Q] = \frac{1}{RC} \cdot t \Rightarrow \ln \frac{Q - 2q}{Q} = \frac{-2}{RC} \cdot t$

$\Rightarrow Q - 2q = Q e^{-2t/RC} \Rightarrow 2q = Q(1 - e^{-2t/RC})$

$\Rightarrow q = \frac{Q}{2} (1 - e^{-2t/RC})$

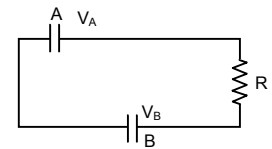

84. The capacitor is given a charge Q. It will discharge and the capacitor will be charged up when connected with battery.

Net charge at time t =  $Qe^{-t/RC} + Q(1 - e^{-t/RC})$ .